



IAQ-Tek

OUTDOOR AIR VOLUME MEASURING SYSTEM

US PATENT # 6,450,043 B1

A complete system for measuring outdoor air intake volume over a wide range of conditions.

- Specifically designed probes operate with minimal straight runs of duct
- Simple installation in a wide variety of intake configurations
- Operates over -40° to 120° F
- Simplified commissioning with built-in setup wizards
- Interfaces with any Building Automation System

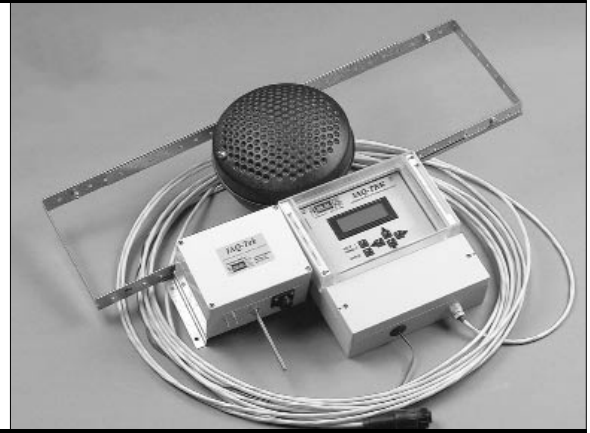

Product Summary

One of the most significant parameters associated with indoor air quality is the volume of fresh outdoor air being drawn into a building through the ventilation system. In most buildings, if indoor air quality is to be assured, the volume of outdoor air must be accurately measured so that it can be controlled.

Existing technologies for measuring airflow volume are better suited for use in supply and exhaust ductwork where filtered air, higher velocities, and straight runs exist. Recognizing this shortcoming, Tek-Air developed a new measurement probe specifically for the low velocities and high turbulence associated with outdoor air intakes.

Coupled with our **IAQ-Tek Transducer and Monitor**, measuring outdoor air volume has never been easier.

Outdoor Air Intake Applications

Whether a custom air handler installed in a penthouse or a commercial rooftop unit, air typically passes through an intake louver, modulating outdoor air damper, and into a return air mixing plenum. Usually the distance between these components is short, and the airflow very turbulent, making the use of conventional measurement devices ineffective.

Complicating matters are the wide variety of intake configurations including louvers, rain hoods, and inlet screens. More simply stated, when it comes to outdoor air, there is never a good location to make an airflow measurement. Furthermore, creating an acceptable measurement location creates a design headache and forces a solution that ends up consuming valuable mechanical space.

Turbulence Tamer Probe

Tek-Air's new patented (#6,450,043 B1) airflow measurement probe is unlike any conventional airflow measurement device and represents a significant departure from previous technology. Used either singly or in multiples, each probe will measure airflow accurately when located in the small space between the intake louvers and the outdoor air damper. Output is not effected by either the turbulence created by the louver, or the modulating damper.

Air moving through the intake impacts the face of the probe, and must then flow around it. A high pressure region is created on the forward surface of the probe. As the air flows around it, a low pressure area is created in the wake of the probe. The difference between these two pressures can be related by calculation to the volume of air being drawn in. Depending on the intake area, one or multiple probes must be used. A simple support system is provided to mount and connect individual probes.



Probes Mounted Before a Damper

Tek-Air Systems, Inc.

41 Eagle Road • Danbury, CT 06810 • (203) 791-1400 • FAX: (203) 798-6534 • SALES FAX: (203) 730-9564 • www.tek-air.com

T-IAQ2000 • 3-04



O.A. Volume Measurement System IAQ2000

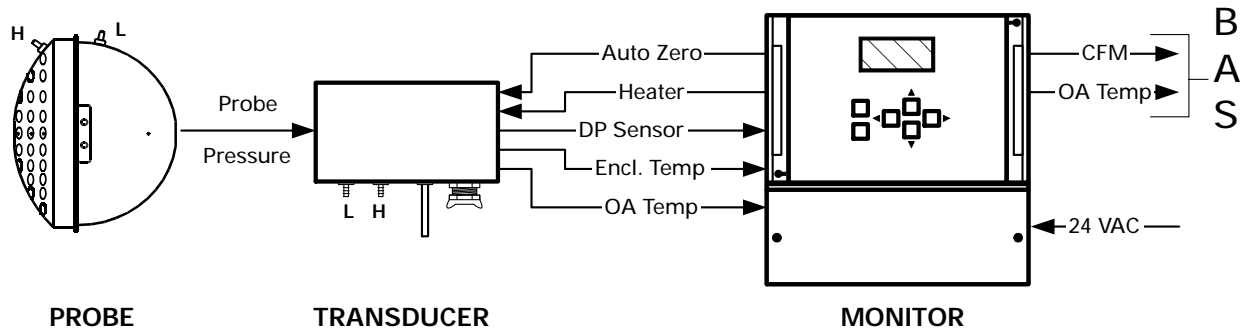

Probes are manufactured of a plastic compound that has a UL fire rating meeting UL-94-VO and UL-94-5VB. Corrosion resistant and self-draining, the probes can be washed with soap and water to remove accumulated dirt.

IAQ-Tek Transducer

The small differential pressure created by the probe must be converted to an electronic signal before it can be utilized for control purposes. This is done in the companion transducer where a high sensitivity micro-machined capacitance sensor converts the low pressures to electronic signals.

The transducer has several other design features that provide performance benefits not found in commercial pressure transmitters. Zero drift is the biggest problem with differential pressure transmitters. To eliminate drift, an auto-zero valve periodically shunts the high and low pressure inputs to the sensor together, creating a zero differential for reference. This sensor output is then measured and subtracted from subsequent readings.

All commercial pressure transmitters exhibit a temperature induced span shift error that decreases their accuracy as the ambient temperature around the device changes. The **IAQ-Tek Transducer** includes a heater circuit to precisely control the sensor temperature so that temperature based shifts are eliminated over the range of 40° to 120° F. The heater also insures that the sensor temperature does not fall below the dewpoint of the air being measured, which can cause damaging condensation.

Because the variations in the outdoor air intake temperature cause the air density to change, volumetric measurements must be temperature compensated. To sense the outdoor air temperature, a thermistor probe is built into the transducer.

Finally, so that the transducer can be mounted in any location, it is housed in a rain tight NEMA-4 enclosure, suitable for mounting outdoors or in the intake plenum. A weatherproof cable assembly is provided to connect the transducer to the monitor.

IAQ-Tek Monitor

While the probes and transducer are the senses of the **IAQ-Tek** system, the monitor provides the brains. All data required to make the outdoor air volume measurement are input to the monitor, including outdoor air temperature, differential pressure, and transducer temperature.

Through two different filtering algorithms, the monitor smoothes and conditions the incoming pressure signals to remove fluctuations caused by wind impacting on the outdoor air intake. The measured variables together with the altitude, area, and probe flow coefficient, are processed by the monitor to calculate the actual volume of outdoor air. An alarm setpoint can be established for the minimum volume of outdoor air.

The monitor requires 24 VAC power, which need not be isolated. Analog outputs transmit the calculated outdoor air volume and temperature measurements to the Building Automation System. An alarm contact output provides status indication for either a low outdoor air volume condition or hardware problem.

The monitor also includes a built-in display that allows the temperature control technician, air balancer, and building owner to easily commission and use the system. All relevant data about the outdoor air can be assessed and viewed by using the 80 character display and intuitive keypad sequences. The display also provides a means to trouble shoot the operation of the hardware.

Diagnostic functions monitor the performance of the differential pressure transducer, auto-zero valve, temperature sensors, and transducer heater. Hardware malfunctions are pinpointed and displayed in the alarm list display.

Setup Wizards

Perhaps the most useful feature of the display is the setup wizards. Three series of preprogrammed instructions lead the temperature control contractor, air balancer, and user through the pertinent setup routines for their commissioning functions. No manuals are required to use the wizards and the chance of inadvertently skipping setup steps is significantly reduced.



O.A. Volume Measurement System IAQ2000

Probe Mounting and Dimensions

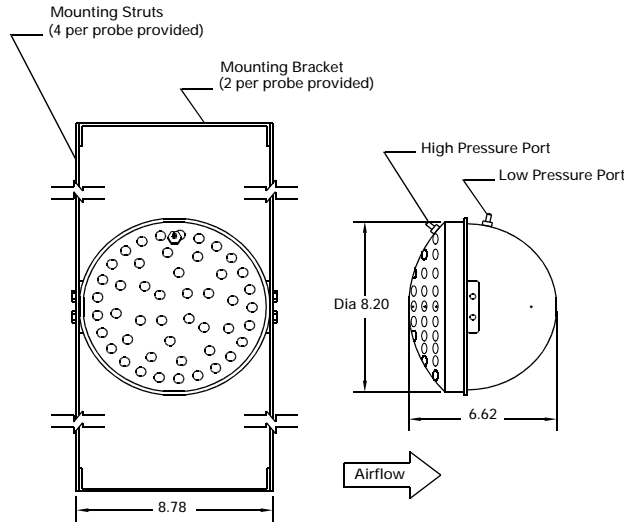

Single Probe Mounting

NOTE: Consult factory for sizes not covered in the chart below. For areas > 100sq. ft., consult the factory.

HOW MANY PROBES TO USE?

To determine the number of probes, use the chart at right. Calculate the aspect ratio first by dividing the longer dimension of the width or height, by the shorter of the two. Then calculate the area in square feet by multiplying the width by height (inches), and dividing by 144 square inches to convert to square feet.

Proceed down the aspect ratio column and compare the area shown to the area calculated. When the calculated area falls between the lowest and highest area in the box, read the number of probes required in the left most column.

# of Probes	Aspect Ratio *		
	1 to 1.5	>1.5 to 2.5	>2.5 to 5
1	to 12 sq.ft.	to 9 sq.ft.	to 6 sq.ft.
2	>12 to 24 sq.ft.	>9 to 22 sq.ft.	>6 to 18 sq.ft.
3	--	--	>18 to 24 sq.ft.
4	>24 to 48 sq.ft.	>22 to 45 sq.ft.	>24 to 30 sq.ft.
5	--	--	>30 to 36 sq.ft.
6	>48 to 64 sq.ft.	>45 to 58 sq.ft.	>36 to 42 sq.ft.
7	--	--	>42 to 48 sq.ft.
8	>64 sq.ft.	>58 sq.ft.	>48 sq.ft.

Transducer and Monitor Dimensional Data

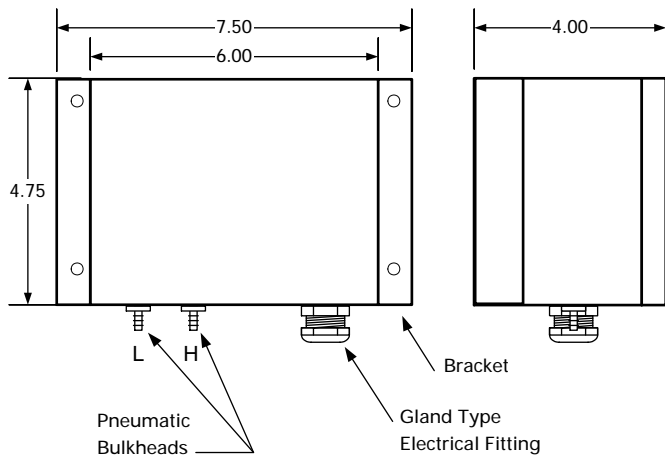

Transducer Dimensions

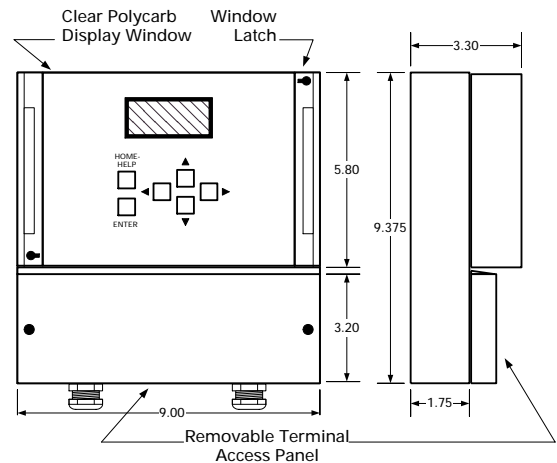

Monitor Dimensions

Tek-Air Systems, Inc.

41 Eagle Road • Danbury, CT 06810 • (203) 791-1400 • FAX: (203) 798-6534 • SALES FAX: (203) 730-9564 • www.tek-air.com

T-IAQ2000 • 3-04



O.A. Volume Measurement System IAQ2000

**NOTE: Consult your local Tek-Air representative for further information.
(for your local representative listing please visit our web site at www.tek-air.com)**

IAQ-Tek Model Code

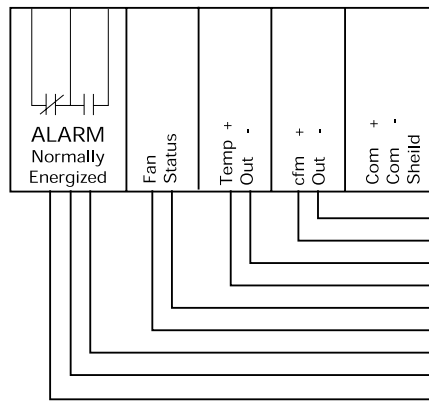
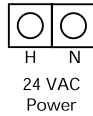
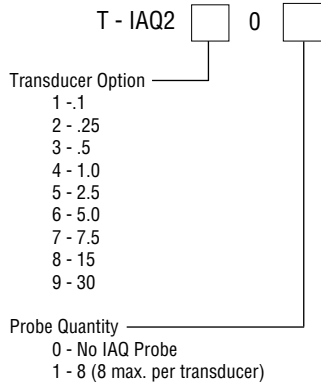

Wiring Diagram

+ cfm to BAS

+ OA Temp. to BAS

Fan Run Contact, NO

Alarm to BAS

Specifications

System Accuracy

Velocity for 0.1" transducer

200 to 1000 fpm; +/- 5% reading
75 to 200 fpm; +/- 10% reading

Higher ranges available. Consult your local representative for more information.

Probe and Transducer

Temperature

Operating: -40 to 120°F
Storage: -40 to 150°F

Air Velocity Capabilities

Discharge of intake louver - 75 to 750 fpm
Free air, before damper - 100 to 1000 fpm

Probe

Material: PVC/ABS
Fire rating: UL-94-VO and UL-94-5VB
Size: 8.5" diameter, 7.5" depth
Weight: 1.5lbs.
Tubing connections: 1/4" barb fittings

Transducer

Enclosure: NEMA-4X water tight
Enclosure size: 6" W x 4.75" H x 3.5" D
Mounting footprint: 7.5" W x 4.75" H
Weight: 1.5 lbs.
Tubing connections: 1/4" barb fittings
Electrical connection: Factory provided integral cable

Monitor

Temperature

Operating: 30 to 110°F
Storage: -40 to 150°F

Enclosure

Type: NEMA-4X water tight
Size: 9" W x 9.5" H x 3.5" D
Mounting footprint: 9.0" W x 9.5" H
Weight: 3.5 lbs.

Power

Supply voltage: 24 VAC, limits 19 to 31 VAC
Power: 25 VA

Digital Input for Fan Status Interlock

Type: Dry Contact

Analog Outputs

Type: Powered and isolated 4-20mA
Scaling:
cfm: user set
temp: -30° to 120°F
Output load: 0-600 ohms

Digital Alarm Output

Type: dry contact, SPDT
Rating: 0.5 amps max.
State: normally energized

Display

Type: LCD, backlit
Size: 4 lines - 20 characters per line

All specifications are subject to change without notice.

Tek-Air Systems, Inc.

41 Eagle Road • Danbury, CT 06810 • (203) 791-1400 • FAX: (203) 798-6534 • SALES FAX: (203) 730-9564 • www.tek-air.com

T-IAQ2000 • 3-04